



STELLAR

20L Planetary mixer





STELLAR

The small planetary mixer that can compete with the bigger ones

Both compact and handy, the new 20-litre Stellar planetary mixer is intended for all craftspeople who want to acquire quality professional equipment, that is less bulky but just as effective as a conventional planetary mixer.

More compact but just as efficient

Stellar was developed with the same specifications as the Saturn 3 range of planetary mixers, namely:

- A stainless steel frame covered with a food grade coating



- Four fixed non-slip feet, including one height-adjustable, for improved stability

- A transparent thermoformed lid in scratch-resistant PMMA* fitted with a hydraulic cylinder-based lid retention system

When comfort of use rhymes with safety

- Two handles on the sides allow easy bowl insertion
- A lever locking system blocks the bowl throughout the cycle. A simple action on the levers releases the bowl
- The tools can be fitted and removed with a single movement, without having to remove the bowl, even when full
- The transparent PMMA* lid limits flour dust, while ensuring user safety when the equipment is in operation
- Removable chute allows additional ingredients to be poured during the cycle without opening the lid

Ergonomic and simple to use equipment

Whether it is the electronic control with a speed variator, the discharge chute or even the access to the tools, everything has been designed such that the user has access from the front to all the elements important to the use of the planetary mixer.

(*)PMMA: Polymethyl methacrylate

Accessories available with Stellar



12-litre reduction kit

With the 12-litre reduction kit, it is now possible to prepare very small quantities. The kit includes a 12-litre bowl and its 3 tools (whip, beater, dough hook). Like the 20-litre model, all the equipment is made of stainless steel for even more robustness.

A stand with storage space

This stand was developed to hold the standard Stellar 20-litre model, along with all of its accessories. It allows optimised storage of tools and the bowl, thus saving space in the bakery. It is mounted on casters for easy moving.

The different tools delivered as standard with the Stellar



Bowl

With a capacity of 20 litres, it allows various preparations to be performed according to the needs of the day. Made of stainless steel, it can easily pass through the pass-through dishwasher, without risk of damage.



Whip

Its diameter has been designed to perfectly emulsify meringues, mousses or light whipped cream as desired, but also sauces, mayonnaises and creams.

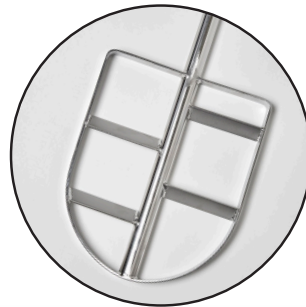

Beater

The tool's geometry, perfectly adapted to the bowl, is ideal for choux pastry, sponge cakes, cookies or any other preparation made from soft dough.



Dough hook

This tool is intended for kneading soft doughs. The hook's special shape keeps preparation time to a minimum, without overheating the dough



STELLAR	
CONTROL TYPE	
Electronic control with speed regulator	•
LID	
Transparent protective lid	•
Hydraulic hood retaining cylinder	•
ALL STAINLESS STEEL EQUIPMENT	
Bowl	•
Whisk	•
Blade	•
Dough hook	•
MAINS VOLTAGE	
230/1/50Hz	•
ACCESSORIES	
Bowl reduction: bowl + 3 tools (whisk, blade, dough hook)	€
Stand with storage space	€

• Standard / € Option with extra cost / - Not available

GENERAL CHARACTERISTICS		
Bowl capacity	(l)	20
Bowl reduction kit: bowl + tools	(l)	12
Power	(kW)	1,1
STELLAR		
DIMENSIONS AND WEIGHT		
Height with lid open (A)	(mm)	1037
Total width (B)	(mm)	572
Total depth (including chute) (C)	(mm)	643
Bowl height (D)	(mm)	314
Height with lid closed (E)	(mm)	870
Distance between front/rear feet (F)	(mm)	393
Bowl diameter	(mm)	320
Weight	(kg)	95

STELLAR + STAND		
DIMENSIONS AND WEIGHT		
Height with lid open (A)	(mm)	1777
Total stand width (L)	(mm)	600
Total depth (including chute) (C)	(mm)	676
Total depth (without chute) (M)	(mm)	629
Height with lid closed (E)	(mm)	1610
Distance between front/rear feet (F)	(mm)	546
Stand height (I)	(mm)	949
Stand + bowl height (D)	(mm)	1054
Weight	(kg)	225

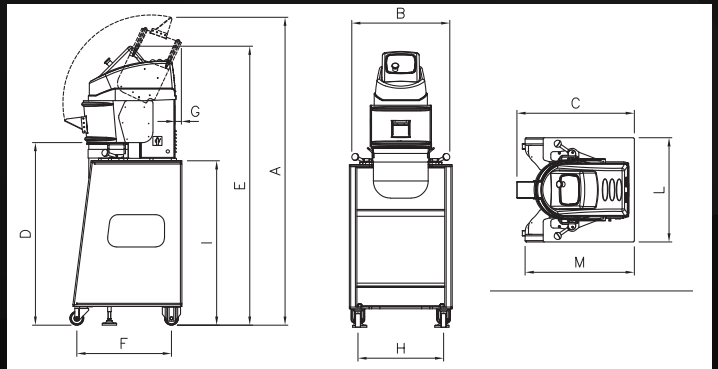
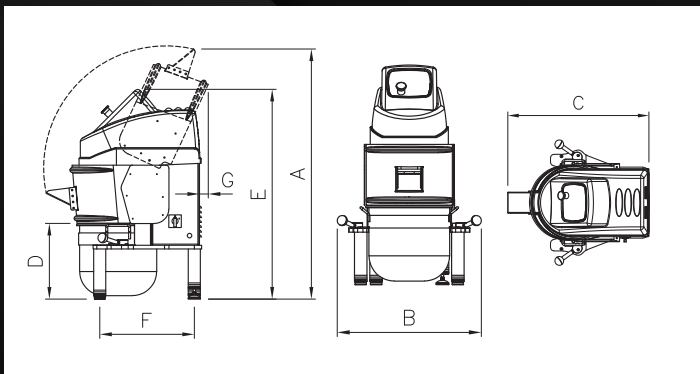

 **BONGARD**

32 route de Wolfisheim - 67810 HOLTZHEIM (FRANCE)
Tel. +33 3 88 78 00 23 - Fax. +33 3 88 76 19 18
www.bongard.fr - bongard@bongard.fr



an Ali Group Company



The Spirit of Excellence